

Diagnostics with Phenomenon

HVAC SYSTEM (AUTO A/C) (DIAGNOSTICS)

6. Diagnostics with Phenomenon

A: INSPECTION

1. Perform the diagnosis according to the diagnostic procedure of the corresponding symptom that is shown in the symptom list.
2. If there are multiple symptoms, perform the diagnosis in the symptom sequence (1 → 2 → ... → 13).

1. SYMPTOM LIST

Symptoms		Diagnostic procedure
1	Nothing is displayed on the screen. No illumination appears on the indicator.	<Ref. to AC(diag)-13, NOTHING IS DISPLAYED ON THE SCREEN. NO ILLUMINATION APPEARS ON THE INDICATOR, DIAGNOSTIC PROCEDURE WITH PHENOMENON, Diagnostics with Phenomenon.>
2	Air conditioner does not stop when pressing the OFF switch.	<Ref. to AC(diag)-15, AIR CONDITIONER DOES NOT STOP WHEN PRESSING THE OFF SWITCH, DIAGNOSTIC PROCEDURE WITH PHENOMENON, Diagnostics with Phenomenon.>
3	Windshield glass does not clear when pressing the DEF switch.	<Ref. to AC(diag)-16, WINDSHIELD GLASS DOES NOT CLEAR WHEN PRESSING THE DEF SWITCH, DIAGNOSTIC PROCEDURE WITH PHENOMENON, Diagnostics with Phenomenon.>
4	Cold air not emitted.	<Ref. to AC(diag)-17, COLD AIR NOT EMITTED, DIAGNOSTIC PROCEDURE WITH PHENOMENON, Diagnostics with Phenomenon.>
5	Warm air not emitted.	<Ref. to AC(diag)-19, WARM AIR NOT EMITTED, DIAGNOSTIC PROCEDURE WITH PHENOMENON, Diagnostics with Phenomenon.>
6	Compartment temperature is lower than setting temperature.	<Ref. to AC(diag)-21, COMPARTMENT TEMPERATURE IS LOWER THAN SETTING TEMPERATURE, DIAGNOSTIC PROCEDURE WITH PHENOMENON, Diagnostics with Phenomenon.>
7	Compartment temperature is higher than setting temperature.	<Ref. to AC(diag)-22, COMPARTMENT TEMPERATURE IS HIGHER THAN SETTING TEMPERATURE, DIAGNOSTIC PROCEDURE WITH PHENOMENON, Diagnostics with Phenomenon.>
8	Air does not come out. Airflow is low. (Blower motor does not rotate.)	<Ref. to AC(diag)-24, AIR DOES NOT COME OUT. AIRFLOW IS LOW, DIAGNOSTIC PROCEDURE WITH PHENOMENON, Diagnostics with Phenomenon.>
9	Airflow cannot be adjusted. (Blower motor turns at a high speed.)	<Ref. to AC(diag)-27, AIR CANNOT BE CONTROLLED, DIAGNOSTIC PROCEDURE WITH PHENOMENON, Diagnostics with Phenomenon.>
10	Cool air does not come out when pressing the A/C switch. Fog cannot be cleared. (Compressor does not operate.)	<Ref. to AC(diag)-29, COOL AIR DOES NOT COME OUT WHEN PRESSING THE A/C SWITCH. FOG CANNOT BE CLEARED. (COMPRESSOR DOES NOT OPERATE.), DIAGNOSTIC PROCEDURE WITH PHENOMENON, Diagnostics with Phenomenon.>
11	Unable to switch suction vents.	<Ref. to AC(diag)-31, UNABLE TO SWITCH SUCTION VENTS, DIAGNOSTIC PROCEDURE WITH PHENOMENON, Diagnostics with Phenomenon.>
12	Unable to switch blow vents.	<Ref. to AC(diag)-32, UNABLE TO SWITCH VENTS, DIAGNOSTIC PROCEDURE WITH PHENOMENON, Diagnostics with Phenomenon.>
13	Illumination does not illuminate or cannot be dimmed.	<Ref. to AC(diag)-33, ILLUMINATION DOES NOT ILLUMINATE OR CANNOT BE DIMMED, DIAGNOSTIC PROCEDURE WITH PHENOMENON, Diagnostics with Phenomenon.>

B: DIAGNOSTIC PROCEDURE WITH PHENOMENON

1. NOTHING IS DISPLAYED ON THE SCREEN. NO ILLUMINATION APPEARS ON THE INDICATOR

TROUBLE SYMPTOM:

- When the AUTO button is pressed with IGN ON, nothing is displayed on the screen or indicators do not illuminate.
- Self diagnosis using A/C control panel does not operate.

TROUBLE CAUSES:

- A/C control panel power supply circuit failure
- CAN communication failure

WIRING DIAGRAM:

Air conditioning system <Ref. to WI-79, WIRING DIAGRAM, Air Conditioning System.>

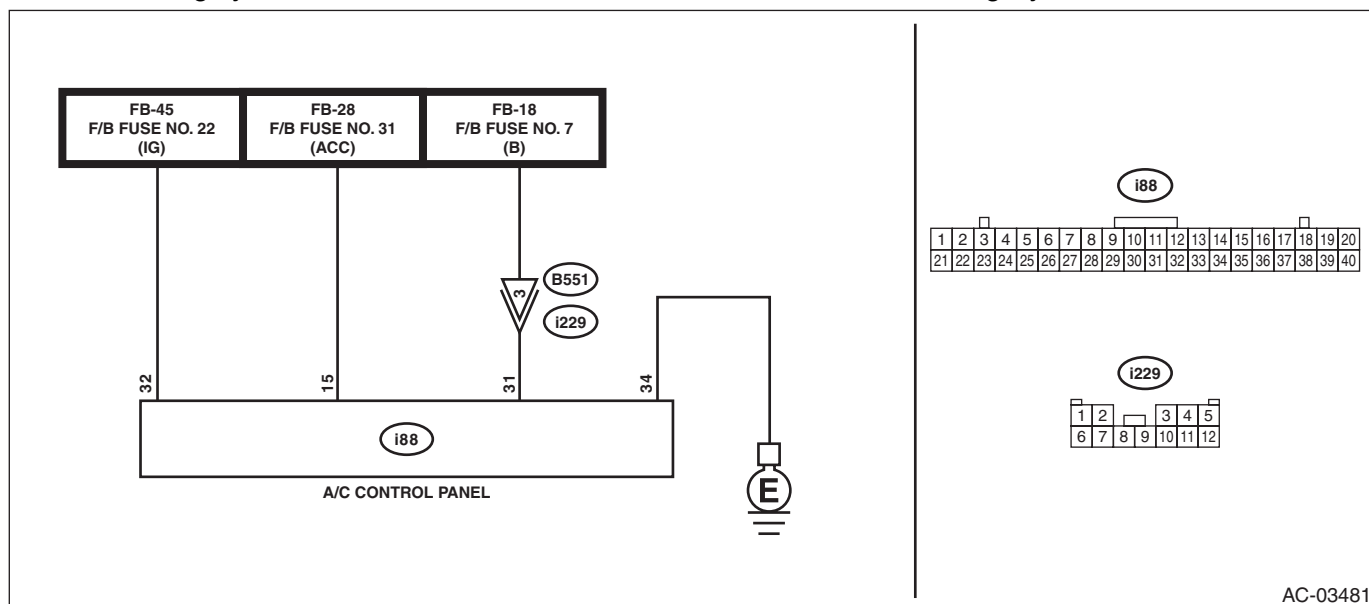

Step	Check	Yes	No
1 CHECK FUSE. 1) Turn the ignition switch to OFF. 2) Remove a fuse from fuse & relay box. 3) Check the condition of fuse.	Is the fuse blown out?	Replace the fuse.	Go to step 2.
2 CHECK CONNECTOR. Check for poor contact of connector.	Is there poor contact of connector?	Repair the connector.	Go to step 3.
3 CHECK A/C CONTROL PANEL POWER CIRCUIT. 1) Remove the A/C control panel. 2) Disconnect the A/C control panel connector. 3) Measure the voltage between A/C control panel connector terminal and chassis ground after turning the ignition switch to ON. <i>Connector & terminal</i> (i88) No. 15 (+) — Chassis ground (-): (i88) No. 31 (+) — Chassis ground (-): (i88) No. 32 (+) — Chassis ground (-):	Is the voltage 10 V or more?	Go to step 4.	Check for open or short circuit in the harness between A/C control panel and fuse.
4 CHECK A/C CONTROL PANEL GROUND CIRCUIT. Measure the resistance of harness between A/C control panel and chassis ground after turning the ignition switch to OFF. <i>Connector & terminal</i> (i88) No. 34 — Chassis ground:	Is the resistance less than 10 Ω?	Go to step 5.	Repair the harness for ground line.

Diagnostics with Phenomenon

HVAC SYSTEM (AUTO A/C) (DIAGNOSTICS)

	Step	Check	Yes	No
5	CHECK FOR POOR CONTACT. Check poor contact of A/C control panel connector.	Is there poor contact of connector?	Repair the connector.	Replace the A/C control panel. <Ref. to AC-44, REMOVAL, Control Panel.>

Diagnostics with Phenomenon

HVAC SYSTEM (AUTO A/C) (DIAGNOSTICS)

2. AIR CONDITIONER DOES NOT STOP WHEN PRESSING THE OFF SWITCH

TROUBLE SYMPTOM:

Blower fan does not switch to OFF, inlet opening does not switch to FRESH, and compressor does not switch to OFF, when pressing the OFF switch.

TROUBLE CAUSE:

- CAN communication failure
- A/C control panel failure
- Blower motor failure
- Intake actuator failure
- Compressor failure

Step	Check	Yes	No
1 CHECK A/C CONTROL PANEL. 1) Turn the ignition switch to ON. 2) Press the OFF switch located on the A/C panel. 3) Check the following data in "Read Current Data" using the Subaru Select Monitor. <ul style="list-style-type: none"> • Blower Fan Level • Fresh/Recircle Air Door Actuator Position Target 	Does "Blower Fan Level" indicate 0 and "Fresh/Recircle Air Door Actuator Position Target" indicate 100%?	Go to step 2.	Replace the A/C control panel. <Ref. to AC-44, REMOVAL, Control Panel.>
2 CHECK BLOWER MOTOR. Check the blower motor operation with the OFF switch pressed.	Does the blower motor stop?	Go to step 3.	<Ref. to AC(diag)-27, AIR CANNOT BE CONTROLLED, DIAGNOSTIC PROCEDURE WITH PHENOMENON, Diagnostics with Phenomenon.>
3 CHECK INTAKE ACTUATOR. Check the intake door operation with the OFF switch pressed.	Is the intake door FRESH?	Go to step 4.	<Ref. to AC(diag)-31, UNABLE TO SWITCH SUCTION VENTS, DIAGNOSTIC PROCEDURE WITH PHENOMENON, Diagnostics with Phenomenon.>
4 CHECK COMPRESSOR. Check the compressor operation with the OFF switch pressed.	Does the compressor stop?	System is normal.	<Ref. to AC(diag)-29, COOL AIR DOES NOT COME OUT WHEN PRESSING THE A/C SWITCH. FOG CANNOT BE CLEARED. (COMPRESSOR DOES NOT OPERATE.), DIAGNOSTIC PROCEDURE WITH PHENOMENON, Diagnostics with Phenomenon.>

Diagnostics with Phenomenon

HVAC SYSTEM (AUTO A/C) (DIAGNOSTICS)

3. WINDSHIELD GLASS DOES NOT CLEAR WHEN PRESSING THE DEF SWITCH

TROUBLE SYMPTOM:

Defroster indicator does not illuminate, outlet opening does not switch to DEF, compressor does not switch to ON, and inlet opening does not switch to FRESH, when pressing the DEF switch.

TROUBLE CAUSES:

- CAN communication failure
- A/C control panel failure
- Mode door actuator failure
- Compressor failure
- Intake door actuator failure

Step	Check	Yes	No
1 CHECK A/C CONTROL PANEL. 1) Turn the ignition switch to ON. 2) Press the DEF switch of the A/C control panel. 3) Using Subaru Select Monitor, check the following data in "Read Current Data". <ul style="list-style-type: none"> • Mode Door Actuator Position Target • Fresh/Recircle Air Door Actuator Position Target 	Does "Mode Door Actuator Position Target" indicate 100% and "Fresh/Recircle Air Door Actuator Position Target" indicate 100%?	Go to step 2.	Replace the A/C control panel. <Ref. to AC-44, REMOVAL, Control Panel.>
2 CHECK MODE DOOR ACTUATOR. With the DEF switch ON, check the mode door operation.	Does the air come out from the DEF outlet opening?	Go to step 3.	<Ref. to AC(diag)-32, UNABLE TO SWITCH VENTS, DIAGNOSTIC PROCEDURE WITH PHENOMENON, Diagnostics with Phenomenon.>
3 CHECK INTAKE DOOR ACTUATOR. With the DEF switch ON, check the FRESH/RECIRC door operation.	Is FRESH/RECIRC switch turned to "FRESH?"	Go to step 4.	<Ref. to AC(diag)-31, UNABLE TO SWITCH SUCTION VENTS, DIAGNOSTIC PROCEDURE WITH PHENOMENON, Diagnostics with Phenomenon.>
4 CHECK COMPRESSOR. With the DEF switch ON, check the compressor operation.	Does the compressor operate?	System is normal.	<Ref. to AC(diag)-29, COOL AIR DOES NOT COME OUT WHEN PRESSING THE A/C SWITCH. FOG CANNOT BE CLEARED. (COMPRESSOR DOES NOT OPERATE.), DIAGNOSTIC PROCEDURE WITH PHENOMENON, Diagnostics with Phenomenon.>

Diagnostics with Phenomenon

HVAC SYSTEM (AUTO A/C) (DIAGNOSTICS)

4. COLD AIR NOT EMITTED

TROUBLE SYMPTOM:

Cold air not emitted.

TROUBLE CAUSES:

- Airflow capacity failure
- Refrigerant pressure failure
- CAN communication failure
- A/C control panel failure
- Air mix actuator RH failure
- Air mix actuator LH failure (only with left/right independent air conditioning function)
- Intake door actuator failure
- Evaporator sensor failure
- In-vehicle sensor failure
- Ambient sensor failure
- Sunload sensor failure

	Step	Check	Yes	No
1	CHECK MAX COOL. Set the A/C control panel dials as follows. Temperature control dial: MAX COOL FRESH/RECIRC switch: RECIRC Mode switch or mode dial: VENT A/C switch: ON	Does no cold air come out?	Go to step 2.	Go to step 4.
2	CHECK AIRFLOW CAPACITY. Check the airflow capacity. <Ref. to AC(diag)-24, AIR DOES NOT COME OUT. AIRFLOW IS LOW, DIAGNOSTIC PROCEDURE WITH PHENOMENON, Diagnostics with Phenomenon.>	Is the airflow capacity normal?	Go to step 3.	Perform repair according to inspection procedure.
3	CHECK AMOUNT OF REFRIGERANT PRESSURE. Check the refrigerant pressure. <Ref. to AC-22, REFRIGERANT GAS PRESSURE INSPECTION, PROCEDURE, Refrigerant Pressure with Manifold Gauge Set.>	Is the refrigerant pressure normal?	Go to step 4.	Perform repair according to refrigerant pressure inspection.
4	CHECK A/C CONTROL PANEL. 1) Turn the temperature control dials (driver's side) and (passenger's side) to MAX COOL. 2) Using Subaru Select Monitor, display the following data in "Read Current Data". <ul style="list-style-type: none"> • Heater Control Panel Setting Value (driver's) • Heater Control Panel Setting Value (passenger's) 	Do "Heater Control Panel Setting Value (Driver's)" and "Heater Control Panel Setting Value (Passenger's)" indicate "60"*1?	Go to step 5.	Replace the A/C control panel. <Ref. to AC-44, REMOVAL, Control Panel.>
5	CHECK A/C CONTROL PANEL. 1) Turn the temperature control dials (driver's side) and (passenger's side) to MAX HOT. 2) Using Subaru Select Monitor, display the following data in "Read Current Data". <ul style="list-style-type: none"> • Heater Control Panel Setting Value (driver's) • Heater Control Panel Setting Value (passenger's) 	Do "Heater Control Panel Setting Value (Driver's)" and "Heater Control Panel Setting Value (Passenger's)" indicate "90"*2?	Go to step 6.	Replace the A/C control panel. <Ref. to AC-44, REMOVAL, Control Panel.>
6	CHECK DTC. 1) Turn the ignition switch to ON. 2) Turn the temperature control dial at MAX COOL and leave for 16 seconds or more. (For vehicles with left/right independent air conditioner, perform setting on both sides.) 3) Read the DTC using Subaru Select Monitor.	Is DTC B14E1, B14E2, B14E3 or B14E4 displayed?	Perform the diagnosis according to DTC.	Go to step 7.

Diagnostics with Phenomenon

HVAC SYSTEM (AUTO A/C) (DIAGNOSTICS)

Step	Check	Yes	No
7 CHECK DTC. 1) Turn the ignition switch to ON. 2) Turn the temperature control dial at MAX HOT and leave for 16 seconds or more. (For vehicles with left/right independent air conditioner, perform setting on both sides.) 3) Read the DTC using Subaru Select Monitor.	Is DTC B14E1, B14E2, B14E3 or B14E4 displayed?	Perform the diagnosis according to DTC.	Go to step 8 .
8 CHECK INTAKE DOOR ACTUATOR. Visually check the intake door actuator operation.	Is the intake door actuator normal?	Go to step 9 .	Check the intake door actuator. <Ref. to AC(diag)-31, UNABLE TO SWITCH SUC-TION VENTS, DIAGNOSTIC PROCEDURE WITH PHENOME-NON, Diagnostics with Phenome-non.>
9 CHECK EVAPORATOR SENSOR UNIT. Perform the inspection of evaporator sensor unit. <Ref. to AC-82, INSPECTION, Evaporator Sensor.>	Is the evaporator sensor normal?	Go to step 10 .	Replace the evaporator sensor. <Ref. to AC-80, REMOVAL, Evaporator Sensor.>
10 CHECK IN-VEHICLE SENSOR UNIT. Check in-vehicle sensor. <Ref. to AC-77, INSPECTION, In-Vehicle Sensor (Auto A/C Model).>	Is the in-vehicle sensor normal?	Go to step 11 .	Replace the in-vehicle sensor. <Ref. to AC-77, REMOVAL, In-Vehicle Sensor (Auto A/C Model).>
11 CHECK AMBIENT SENSOR UNIT. Check the ambient sensor. <Ref. to AC-74, INSPECTION, Ambient Sensor.>	Is the ambient sensor normal?	Go to step 12 .	Replace the ambient sensor. <Ref. to AC-72, REMOVAL, Ambient Sensor.>
12 CHECK SUNLOAD SENSOR UNIT. Check the sunload sensor unit. <Ref. to AC-76, INSPECTION, Sunload Sensor (Auto A/C Model).>	Is the sunload sensor normal?	System is normal.	Replace the sunload sensor. <Ref. to AC-75, REMOVAL, Sunload Sensor (Auto A/C Model).>

*1: For the 75°F center specification. Note that 18 for the 25°C center specification

*2: For the 75°F center specification. Note that 32 for the 25°C center specification

Diagnostics with Phenomenon

HVAC SYSTEM (AUTO A/C) (DIAGNOSTICS)

5. WARM AIR NOT EMITTED

TROUBLE SYMPTOM:

Warm air not emitted.

TROUBLE CAUSES:

- Airflow capacity failure
- Coolant level failure
- CAN communication failure
- A/C control panel failure
- Air mix actuator RH failure
- Air mix actuator LH failure (only with left/right independent air conditioning function)
- Intake door actuator failure
- Evaporator sensor failure
- In-vehicle sensor failure
- Ambient sensor failure
- Sunload sensor failure

	Step	Check	Yes	No
1	CHECK MAX HOT. Set the A/C control panel dials as follows. Temperature control dial: MAX HOT FRESH/RECIRC switch: FRESH Mode switch or mode dial: HEAT A/C switch: OFF	Does it fail to blow the hot air?	Go to step 2.	Go to step 4.
2	CHECK AIRFLOW CAPACITY. Check the airflow capacity. <Ref. to AC(diag)-24, AIR DOES NOT COME OUT. AIRFLOW IS LOW, DIAGNOSTIC PROCEDURE WITH PHENOMENON, Diagnostics with Phenomenon.>	Is the airflow capacity normal?	Go to step 3.	Perform repair according to inspection procedure.
3	CHECK ENGINE COOLANT. Check engine coolant amount.	Is the engine coolant level within the specification?	Go to step 4.	Fill engine coolant. If there is coolant leakage, repair the leaks according to Engine Cooling System Trouble in General. <Ref. to CO(w/o STI)-53, Engine Cooling System Trouble in General.> <Ref. to CO(STI)-29, Engine Cooling System Trouble in General.>
4	CHECK A/C CONTROL PANEL. 1) Turn the temperature control dials (driver's side) and (passenger's side) to MAX COOL. 2) Using Subaru Select Monitor, display the following data in "Read Current Data". <ul style="list-style-type: none"> • Heater Control Panel Setting Value (driver's) • Heater Control Panel Setting Value (passenger's) 	Do "Heater Control Panel Setting Value (Driver's)" and "Heater Control Panel Setting Value (Passenger's)" indicate "60"*1?	Go to step 5.	Replace the A/C control panel. <Ref. to AC-44, REMOVAL, Control Panel.>

Diagnostics with Phenomenon

HVAC SYSTEM (AUTO A/C) (DIAGNOSTICS)

Step	Check	Yes	No
5 CHECK A/C CONTROL PANEL. 1) Turn the temperature control dials (driver's side) and (passenger's side) to MAX HOT. 2) Using Subaru Select Monitor, display the following data in "Read Current Data". <ul style="list-style-type: none"> • Heater Control Panel Setting Value (driver's) • Heater Control Panel Setting Value (passenger's) 	Do "Heater Control Panel Setting Value (Driver's)" and "Heater Control Panel Setting Value (Passenger's)" indicate "90"*2?	Go to step 6.	Replace the A/C control panel. <Ref. to AC-44, REMOVAL, Control Panel.>
6 CHECK DTC. 1) Turn the ignition switch to ON. 2) Turn the temperature control dial at MAX COOL and leave for 16 seconds or more. (For vehicles with left/right independent air conditioner, perform setting on both sides.) 3) Read the DTC using Subaru Select Monitor.	Is DTC B14E1, B14E2, B14E3 or B14E4 displayed?	Perform the diagnosis according to DTC.	Go to step 7.
7 CHECK DTC. 1) Turn the ignition switch to ON. 2) Turn the temperature control dial at MAX HOT and leave for 16 seconds or more. (For vehicles with left/right independent air conditioner, perform setting on both sides.) 3) Read the DTC using Subaru Select Monitor.	Is DTC B14E1, B14E2, B14E3 or B14E4 displayed?	Perform the diagnosis according to DTC.	Go to step 8.
8 CHECK INTAKE DOOR ACTUATOR. Visually check the intake door actuator operation.	Is the intake door actuator normal?	Go to step 9.	Check the intake door actuator. <Ref. to AC(diag)-31, UNABLE TO SWITCH SUCTION VENTS, DIAGNOSTIC PROCEDURE WITH PHENOMENON, Diagnostics with Phenomenon.>
9 CHECK EVAPORATOR SENSOR UNIT. Perform the inspection of evaporator sensor unit. <Ref. to AC-82, INSPECTION, Evaporator Sensor.>	Is the evaporator sensor normal?	Go to step 10.	Replace the evaporator sensor. <Ref. to AC-80, REMOVAL, Evaporator Sensor.>
10 CHECK IN-VEHICLE SENSOR UNIT. Check in-vehicle sensor circuit. <Ref. to AC-77, INSPECTION, In-Vehicle Sensor (Auto A/C Model).>	Is the in-vehicle sensor circuit normal?	Go to step 11.	Replace the in-vehicle sensor. <Ref. to AC-77, REMOVAL, In-Vehicle Sensor (Auto A/C Model).>
11 CHECK AMBIENT SENSOR UNIT. Check the ambient sensor. <Ref. to AC-74, INSPECTION, Ambient Sensor.>	Is the ambient sensor normal?	Go to step 12.	Replace the ambient sensor. <Ref. to AC-72, REMOVAL, Ambient Sensor.>
12 CHECK SUNLOAD SENSOR UNIT. Check the sunload sensor unit. <Ref. to AC-76, INSPECTION, Sunload Sensor (Auto A/C Model).>	Is the sunload sensor normal?	System is normal.	Replace the sunload sensor. <Ref. to AC-75, REMOVAL, Sunload Sensor (Auto A/C Model).>

*1: For the 75°F center specification. Note that 18 for the 25°C center specification

*2: For the 75°F center specification. Note that 32 for the 25°C center specification

Diagnostics with Phenomenon

HVAC SYSTEM (AUTO A/C) (DIAGNOSTICS)

6. COMPARTMENT TEMPERATURE IS LOWER THAN SETTING TEMPERATURE

TROUBLE SYMPTOM:

Compartment temperature is excessively lower than setting temperature.

TROUBLE CAUSES:

- Large airflow capacity
- Refrigerant pressure failure
- CAN communication failure
- A/C control panel failure
- Air mix actuator RH failure
- Air mix actuator LH failure (only with left/right independent air conditioning function)
- Evaporator sensor failure
- In-vehicle sensor failure
- Ambient sensor failure
- Sunload sensor failure

Step	Check	Yes	No
1 CHECK AIRFLOW CAPACITY. Check the airflow capacity. <Ref. to AC(diag)-27, AIR CANNOT BE CONTROLLED, DIAGNOSTIC PROCEDURE WITH PHENOMENON, Diagnostics with Phenomenon.>	Is the airflow capacity normal?	Go to step 2.	Perform repair according to inspection procedure.
2 CHECK AMOUNT OF REFRIGERANT PRESSURE. Check the refrigerant pressure. <Ref. to AC-22, REFRIGERANT GAS PRESSURE INSPECTION, PROCEDURE, Refrigerant Pressure with Manifold Gauge Set.>	Is the refrigerant pressure normal?	Go to step 3.	Perform repair according to refrigerant pressure inspection.
3 CHECK A/C CONTROL PANEL. 1) Turn the temperature control dials (driver's side) and (passenger's side) to MAX COOL. 2) Using Subaru Select Monitor, display the following data in "Read Current Data". <ul style="list-style-type: none"> • Heater Control Panel Setting Value (driver's) • Heater Control Panel Setting Value (passenger's) 	Do "Heater Control Panel Setting Value (Driver's)" and "Heater Control Panel Setting Value (Passenger's)" indicate "60"*1?	Go to step 4.	Replace the A/C control panel. <Ref. to AC-44, REMOVAL, Control Panel.>
4 CHECK A/C CONTROL PANEL. 1) Turn the temperature control dials (driver's side) and (passenger's side) to MAX HOT. 2) Using Subaru Select Monitor, display the following data in "Read Current Data". <ul style="list-style-type: none"> • Heater Control Panel Setting Value (driver's) • Heater Control Panel Setting Value (passenger's) 	Do "Heater Control Panel Setting Value (Driver's)" and "Heater Control Panel Setting Value (Passenger's)" indicate "90"*2?	Go to step 5.	Replace the A/C control panel. <Ref. to AC-44, REMOVAL, Control Panel.>
5 CHECK DTC. 1) Turn the ignition switch to ON. 2) Turn the temperature control dial at MAX COOL and leave for 16 seconds or more. (For vehicles with left/right independent air conditioner, perform setting on both sides.) 3) Read the DTC using Subaru Select Monitor.	Is DTC B14E1, B14E2, B14E3 or B14E4 displayed?	Perform the diagnosis according to DTC.	Go to step 6.
6 CHECK DTC. 1) Turn the ignition switch to ON. 2) Turn the temperature control dial at MAX HOT and leave for 16 seconds or more. (For vehicles with left/right independent air conditioner, perform setting on both sides.) 3) Read the DTC using Subaru Select Monitor.	Is DTC B14E1, B14E2, B14E3 or B14E4 displayed?	Perform the diagnosis according to DTC.	Go to step 7.

Diagnostics with Phenomenon

HVAC SYSTEM (AUTO A/C) (DIAGNOSTICS)

Step	Check	Yes	No	
7	CHECK EVAPORATOR SENSOR UNIT. Perform the inspection of evaporator sensor unit. <Ref. to AC-82, INSPECTION, Evaporator Sensor.>	Is the evaporator sensor normal?	Go to step 8 .	Replace the evaporator sensor. <Ref. to AC-80, REMOVAL, Evaporator Sensor.>
8	CHECK IN-VEHICLE SENSOR UNIT. Check in-vehicle sensor circuit. <Ref. to AC-77, INSPECTION, In-Vehicle Sensor (Auto A/C Model).>	Is the in-vehicle sensor circuit normal?	Go to step 9 .	Replace the in-vehicle sensor. <Ref. to AC-77, REMOVAL, In-Vehicle Sensor (Auto A/C Model).>
9	CHECK AMBIENT SENSOR UNIT. Check the ambient sensor. <Ref. to AC-74, INSPECTION, Ambient Sensor.>	Is the ambient sensor normal?	Go to step 10 .	Replace the ambient sensor. <Ref. to AC-72, REMOVAL, Ambient Sensor.>
10	CHECK SUNLOAD SENSOR UNIT. Check the sunload sensor unit. <Ref. to AC-76, INSPECTION, Sunload Sensor (Auto A/C Model).>	Is the sunload sensor normal?	System is normal.	Replace the sunload sensor. <Ref. to AC-75, REMOVAL, Sunload Sensor (Auto A/C Model).>

*1: For the 75°F center specification. Note that 18 for the 25°C center specification

*2: For the 75°F center specification. Note that 32 for the 25°C center specification

7. COMPARTMENT TEMPERATURE IS HIGHER THAN SETTING TEMPERATURE

TROUBLE SYMPTOM:

Compartment temperature is excessively higher than setting temperature.

TROUBLE CAUSES:

- Large airflow capacity
- CAN communication failure
- A/C control panel failure
- Air mix actuator RH failure
- Air mix actuator LH failure (only with left/right independent air conditioning function)
- Intake door actuator failure
- Evaporator sensor failure
- In-vehicle sensor failure
- Ambient sensor failure
- Sunload sensor failure

Step	Check	Yes	No	
1	CHECK AIRFLOW CAPACITY. Check the airflow capacity. <Ref. to AC(diag)-27, AIR CANNOT BE CONTROLLED, DIAGNOSTIC PROCEDURE WITH PHENOMENON, Diagnostics with Phenomenon.>	Is the airflow capacity normal?	Go to step 2 .	Perform repair according to inspection procedure.
2	CHECK A/C CONTROL PANEL. 1) Turn the temperature control dials (driver's side) and (passenger's side) to MAX COOL. 2) Using Subaru Select Monitor, display the following data in "Read Current Data". • Heater Control Panel Setting Value (driver's) • Heater Control Panel Setting Value (passenger's)	Do "Heater Control Panel Setting Value (Driver's)" and "Heater Control Panel Setting Value (Passenger's)" indicate "60"*1?	Go to step 3 .	Replace the A/C control panel. <Ref. to AC-44, REMOVAL, Control Panel.>

Diagnostics with Phenomenon

HVAC SYSTEM (AUTO A/C) (DIAGNOSTICS)

Step	Check	Yes	No
3 CHECK A/C CONTROL PANEL. 1) Turn the temperature control dials (driver's side) and (passenger's side) to MAX HOT. 2) Using Subaru Select Monitor, display the following data in "Read Current Data". <ul style="list-style-type: none"> • Heater Control Panel Setting Value (driver's) • Heater Control Panel Setting Value (passenger's) 	Do "Heater Control Panel Setting Value (Driver's)" and "Heater Control Panel Setting Value (Passenger's)" indicate "90"*2?	Go to step 4.	Replace the A/C control panel. <Ref. to AC-44, REMOVAL, Control Panel.>
4 CHECK DTC. 1) Turn the ignition switch to ON. 2) Turn the temperature control dial at MAX COOL and leave for 16 seconds or more. (For vehicles with left/right independent air conditioner, perform setting on both sides.) 3) Read the DTC using Subaru Select Monitor.	Is DTC B14E1, B14E2, B14E3 or B14E4 displayed?	Perform the diagnosis according to DTC.	Go to step 5.
5 CHECK DTC. 1) Turn the ignition switch to ON. 2) Turn the temperature control dial at MAX HOT and leave for 16 seconds or more. (For vehicles with left/right independent air conditioner, perform setting on both sides.) 3) Read the DTC using Subaru Select Monitor.	Is DTC B14E1, B14E2, B14E3 or B14E4 displayed?	Perform the diagnosis according to DTC.	Go to step 6.
6 CHECK INTAKE DOOR ACTUATOR. Visually check the intake door actuator operation.	Is the intake door actuator normal?	Go to step 7.	Check the intake door actuator. <Ref. to AC(diag)-31, UNABLE TO SWITCH SUCTION VENTS, DIAGNOSTIC PROCEDURE WITH PHENOMENON, Diagnostics with Phenomenon.>
7 CHECK EVAPORATOR SENSOR UNIT. Perform the inspection of evaporator sensor unit. <Ref. to AC-82, INSPECTION, Evaporator Sensor.>	Is the evaporator sensor normal?	Go to step 8.	Replace the evaporator sensor. <Ref. to AC-80, REMOVAL, Evaporator Sensor.>
8 CHECK IN-VEHICLE SENSOR UNIT. Check in-vehicle sensor circuit. <Ref. to AC-77, INSPECTION, In-Vehicle Sensor (Auto A/C Model).>	Is the in-vehicle sensor circuit normal?	Go to step 9.	Replace the in-vehicle sensor. <Ref. to AC-77, REMOVAL, In-Vehicle Sensor (Auto A/C Model).>
9 CHECK AMBIENT SENSOR UNIT. Check the ambient sensor. <Ref. to AC-74, INSPECTION, Ambient Sensor.>	Is the ambient sensor normal?	Go to step 10.	Replace the ambient sensor. <Ref. to AC-72, REMOVAL, Ambient Sensor.>
10 CHECK SUNLOAD SENSOR UNIT. Check the sunload sensor unit. <Ref. to AC-76, INSPECTION, Sunload Sensor (Auto A/C Model).>	Is the sunload sensor normal?	System is normal.	Replace the sunload sensor. <Ref. to AC-75, REMOVAL, Sunload Sensor (Auto A/C Model).>

*1: For the 75°F center specification. Note that 18 for the 25°C center specification

*2: For the 75°F center specification. Note that 32 for the 25°C center specification

Diagnostics with Phenomenon

HVAC SYSTEM (AUTO A/C) (DIAGNOSTICS)

8. AIR DOES NOT COME OUT. AIRFLOW IS LOW

TROUBLE SYMPTOM:

- Airflow capacity is insufficient.
- Air does not come out when operating the fan dial.

TROUBLE CAUSES:

- Airflow capacity failure
- CAN communication failure
- A/C control panel failure
- Blower motor failure

WIRING DIAGRAM:

Air conditioning system <Ref. to WI-79, WIRING DIAGRAM, Air Conditioning System.>

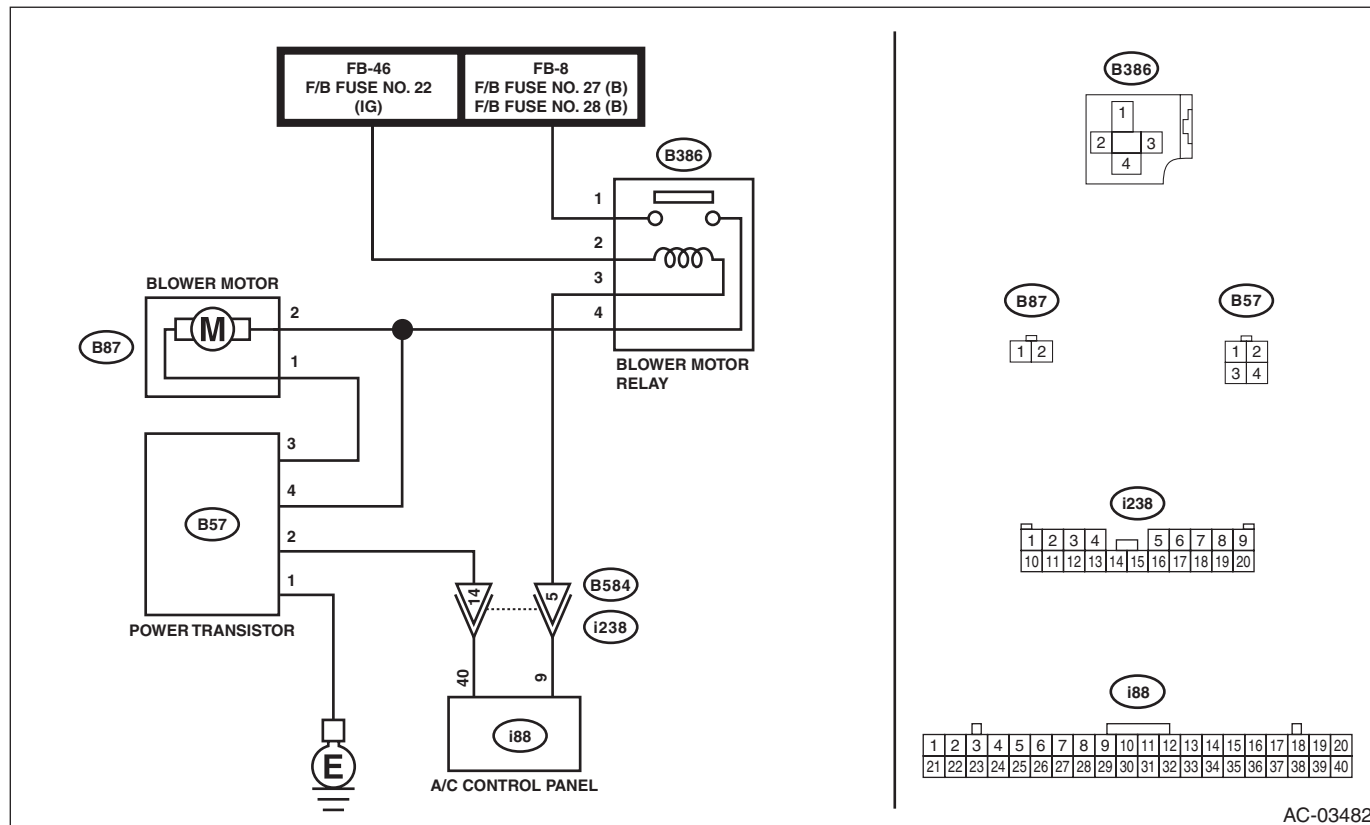

AC-03482

Step	Check	Yes	No
1	CHECK A/C CONTROL PANEL. 1) Using Subaru Select Monitor, display the following data in "Read Current Data". <ul style="list-style-type: none"> • Air mix door actuator position (driver's side) • Air mix door actuator position (passenger's) • Blower fan level 2) Turn the temperature control dial at MAX COOL and increase and decrease the A/C control panel fan dial. (For vehicles with left/right independent air conditioner, perform setting on both sides.)	Go to step 2.	Go to step 5.
2	CHECK AIRFLOW CAPACITY. Turn the temperature control dial to LO (both dials for the models equipped with left/right independent air conditioning function), A/C control panel fan dial to MAX and FRESH/RECIRC switch to RECIRC.	Go to step 3.	System is normal.
3	CHECK A/C FILTER. Check the A/C filter.	Go to step 4.	Clean or replace the A/C filter.

Diagnostics with Phenomenon

HVAC SYSTEM (AUTO A/C) (DIAGNOSTICS)

Step	Check	Yes	No
4 CHECK EACH DUCT. Check each duct joint for disconnection or clogging.	Is each duct normal?	Go to step 5.	Repair the faulty duct.
5 CHECK A/C CONTROL PANEL. 1) Turn the ignition switch to ON. 2) Turn the fan dial to the maximum position. 3) Using the Subaru Select Monitor, check "Blower Fan Level" of the current data from the A/C diagnosis.	Does "Blower Fan Level" indicate "7"?	Go to step 6.	Replace the A/C control panel. <Ref. to AC-44, REMOVAL, Control Panel.>
6 CHECK A/C CONTROL PANEL. 1) Turn the fan dial to the minimum position. 2) Using the Subaru Select Monitor, check "Blower Fan Level" of the current data from the A/C diagnosis.	Does "Blower Fan Level" indicate "1"?	Go to step 7.	Replace the A/C control panel. <Ref. to AC-44, REMOVAL, Control Panel.>
7 CHECK CONNECTOR. Check for poor contact of connector.	Is there poor contact of connector?	Repair the connector.	Go to step 8.
8 CHECK FUSE. 1) Remove a fuse in the fuse & relay box. 2) Check the condition of fuse.	Is the fuse blown out?	Replace the fuse.	Go to step 9.
9 CHECK BLOWER MOTOR RELAY ON SIGNAL. 1) Stop the engine. 2) Turn the fan dial OFF. 3) Turn the ignition switch to ON. 4) Using a tester, measure the voltage between the A/C control panel connector (i88) and chassis ground. Connector & terminal (i88) No. 9 (+) — Chassis ground (-):	Is the voltage 10 V or more?	Go to step 10.	<ul style="list-style-type: none"> • Check for open or short circuit in the harness between fuse and ECM. • Check the blower relay connector and relay unit. <Ref. to AC-33, CHECK RELAY, INSPECTION, Relay and Fuse.>
10 CHECK BLOWER MOTOR RELAY ON SIGNAL. 1) Start the engine. 2) Turn the fan dial to ON. 3) Using a tester, measure the voltage between the A/C control panel connector (i88) and chassis ground. Connector & terminal (i88) No. 9 (+) — Chassis ground (-):	Is the voltage 0 V?	Go to step 11.	Replace the A/C control panel. <Ref. to AC-44, REMOVAL, Control Panel.>
11 CHECK BLOWER MOTOR POWER SUPPLY CIRCUIT. 1) Turn the ignition switch to ON. 2) Turn the fan dial to ON. 3) Use a tester to measure the voltage between the blower motor connector (B87) and chassis ground. Connector & terminal (B87) No. 2 (+) — Chassis ground (-):	Is the voltage 10 V or more?	Go to step 12.	<ul style="list-style-type: none"> • Check the blower motor power supply line harness for open circuit or connector disconnection. • Check the blower relay connector and relay unit. <Ref. to AC-33, CHECK RELAY, INSPECTION, Relay and Fuse.>
12 CHECK BLOWER MOTOR UNIT. Check the blower motor. <Ref. to AC-37, INSPECTION, Blower Motor.>	Is the blower motor OK?	Go to step 13.	Replace the blower motor. <Ref. to AC-37, REMOVAL, Blower Motor.>

Diagnostics with Phenomenon

HVAC SYSTEM (AUTO A/C) (DIAGNOSTICS)

Step	Check	Yes	No
13 CHECK HARNESS. 1) Disconnect the power transistor and A/C control panel connector. 2) Using a tester, measure the resistance between harness terminals. <i>Connector & terminal</i> <i>(B386) No. 4 — (B57) No. 4:</i> <i>(B87) No. 1 — (B57) No. 3:</i> <i>(B57) No. 2 — (i88) No. 40:</i> <i>(B57) No. 1 — Chassis ground:</i>	Is the resistance less than 1 Ω ?	Go to step 14.	Repair or replace the open circuit of harness.
14 CHECK HARNESS. Use a tester to measure the harness resistance between the power transistor connector and chassis ground. <i>Connector & terminal</i> <i>(B57) No. 2 — Chassis ground:</i>	Is the resistance less than 1 Ω ?	Repair or replace the short circuit of the harness.	Go to step 15.
15 CHECK POWER TRANSISTOR. Replace the power transistor with a properly functioning part.	Does the blower motor rotate?	Replace the power transistor. <Ref. to AC-38, REMOVAL, Power Transistor (Auto A/C Model).>	Replace the A/C control panel. <Ref. to AC-44, REMOVAL, Control Panel.>

Diagnostics with Phenomenon

9. AIR CANNOT BE CONTROLLED

TROUBLE SYMPTOM:

- The blower rotates even though the blower switch is not turned on.
- The blower motor continues to rotate at high speed. (Not adjustable.)

TROUBLE CAUSES:

- Airflow capacity failure
- CAN communication failure
- A/C control panel failure
- Blower motor failure

WIRING DIAGRAM:

Air conditioning system <Ref. to WI-79, WIRING DIAGRAM, Air Conditioning System.>

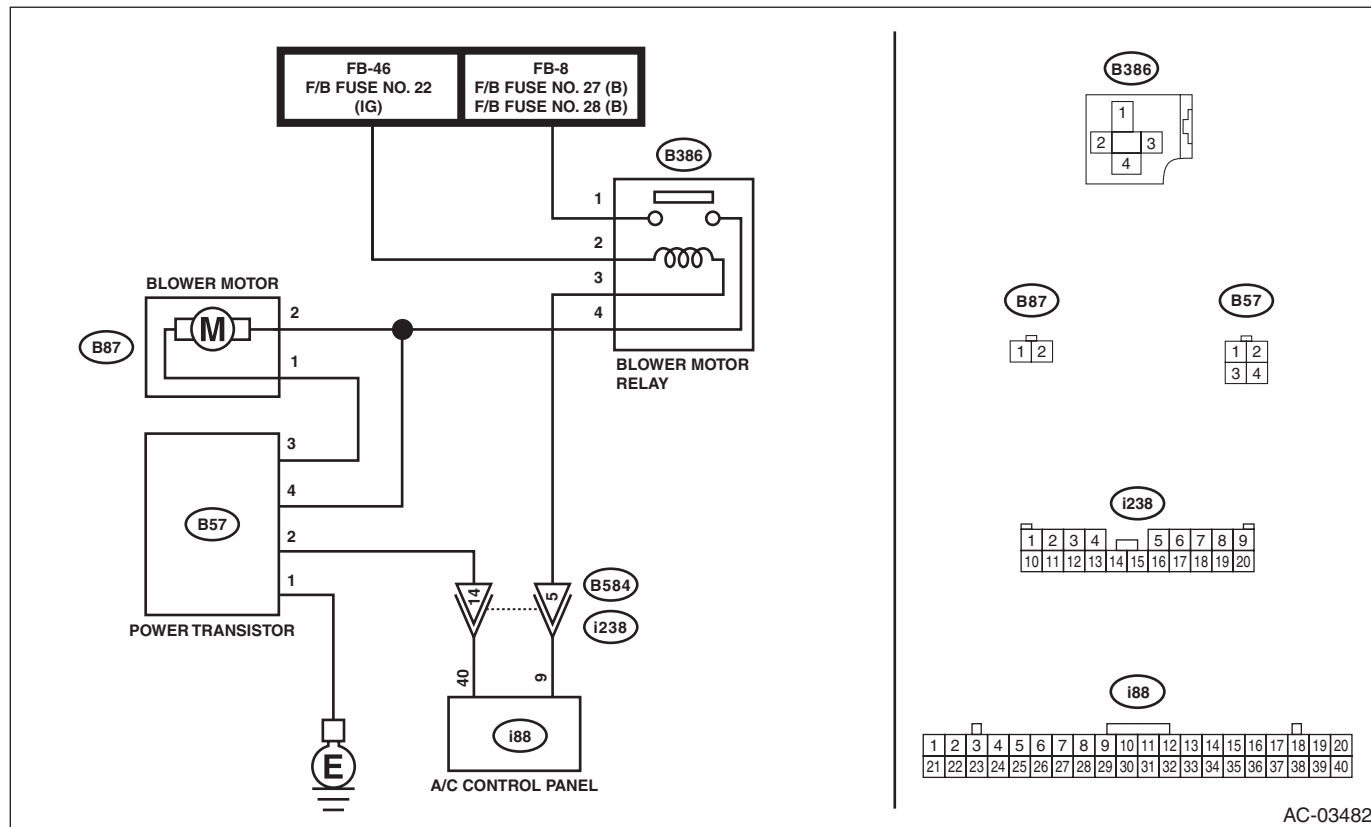

AC-03482

Step	Check	Yes	No
1 CHECK A/C CONTROL PANEL. 1) Turn the ignition switch to ON. 2) Turn the fan dial to the maximum position. 3) Using the Subaru Select Monitor, check "Blower Fan Level" of the current data from the A/C diagnosis.	Does "Blower Fan Level" indicate "7"?	Go to step 2.	Replace the A/C control panel. <Ref. to AC-44, REMOVAL, Control Panel.>
2 CHECK A/C CONTROL PANEL. 1) Turn the fan dial to the minimum position. 2) Using the Subaru Select Monitor, check "Blower Fan Level" of the current data from the A/C diagnosis.	Does "Blower Fan Level" indicate "1"?	Go to step 3.	Replace the A/C control panel. <Ref. to AC-44, REMOVAL, Control Panel.>
3 CHECK HARNESS. 1) Turn the ignition switch to OFF. 2) Disconnect the power transistor connector. 3) Use a tester to measure the resistance between the power transistor connector and chassis ground. Connector & terminal (B57) No. 4 — Chassis ground:	Is the resistance less than 1 Ω?	Repair or replace the short circuit of the harness between blower motor and power transistor.	Go to step 4.

Diagnostics with Phenomenon

HVAC SYSTEM (AUTO A/C) (DIAGNOSTICS)

Step	Check	Yes	No
4 CHECK HARNESS. 1) Remove the A/C control panel. 2) Turn the ignition switch to ON. 3) Use a tester to measure the resistance between the power transistor connector and chassis ground. Connector & terminal (B57) No. 2 — Chassis ground:	Is the resistance less than 1 Ω ?	Repair or replace the short circuit of the harness between A/C control panel and power transistor.	Go to step 5.
5 CHECK HARNESS. 1) Connect the disconnected connectors. 2) Turn the ignition switch to ON. 3) Use a tester to measure the voltage between the power transistor connector and chassis ground. Connector & terminal (B57) No. 2 (+) — Chassis ground (-):	Is the voltage approx. 9 V when fan dial in 1st, and approx. 3.5 V when fan dial in 6th?	Replace the power transistor. <Ref. to AC-38, REMOVAL, Power Transistor (Auto A/C Model).>	Go to step 6.
6 CHECK A/C CONTROL PANEL. 1) Turn the fan dial OFF. 2) Disconnect the power transistor connector. 3) Use a tester to measure the resistance between the power transistor connector and chassis ground. Connector & terminal (B57) No. 2 — Chassis ground:	When the fan dial is OFF and other than OFF, does the resistance change?	Replace the power transistor. <Ref. to AC-38, REMOVAL, Power Transistor (Auto A/C Model).>	Replace the A/C control panel. <Ref. to AC-44, REMOVAL, Control Panel.>

Diagnostics with Phenomenon

HVAC SYSTEM (AUTO A/C) (DIAGNOSTICS)

10. COOL AIR DOES NOT COME OUT WHEN PRESSING THE A/C SWITCH. FOG CANNOT BE CLEARED. (COMPRESSOR DOES NOT OPERATE.)

TROUBLE SYMPTOM:

Compressor does not operate after turning the A/C switch to ON and fan dial between LO and HI.

TROUBLE CAUSES:

Compressor failure

WIRING DIAGRAM:

Air conditioning system <Ref. to WI-79, WIRING DIAGRAM, Air Conditioning System.>

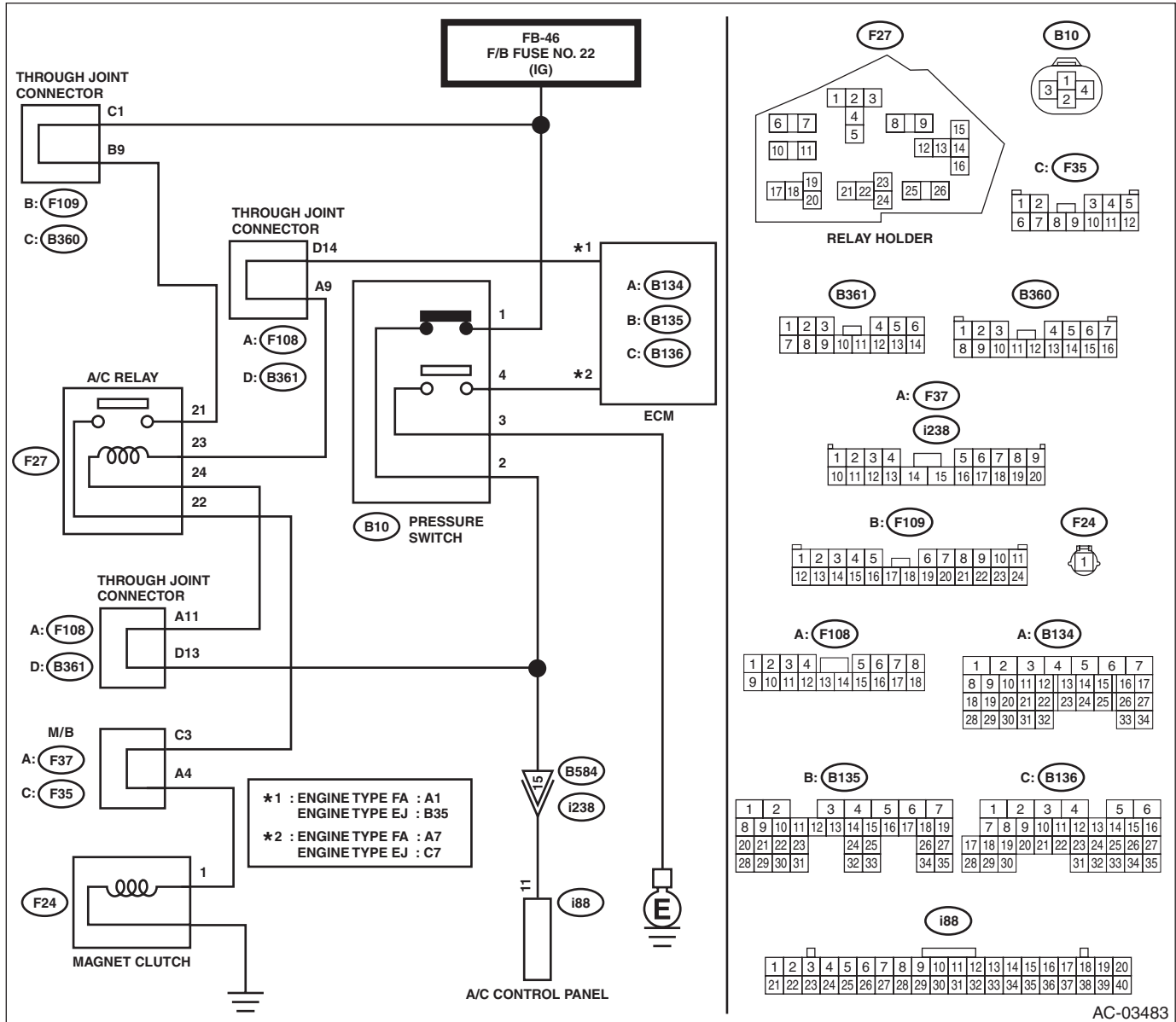

Step	Check	Yes	No	
1	CHECK A/C CONTROL PANEL. 1) Leave the vehicle under the condition at ambient temperature of 15°C (59°F) or more. 2) Turn the ignition switch to ON. 3) Turn the fan dial to the maximum position. 4) Press the A/C switch.	Is "A/C" displayed on the A/C control panel?	Go to step 2.	Replace the A/C control panel. <Ref. to AC-44, REMOVAL, Control Panel.>

Diagnostics with Phenomenon

HVAC SYSTEM (AUTO A/C) (DIAGNOSTICS)

Step	Check	Yes	No
2 CHECK EVAPORATOR SENSOR. Using the Subaru Select Monitor, check "Evaporator Temp." of the current data from the A/C diagnosis.	Does the data indicate -0.5 degree or more?	Go to step 4.	Go to step 3.
3 CHECK EVAPORATOR SENSOR. Check the evaporator sensor. <Ref. to AC-82, INSPECTION, Evaporator Sensor.>	Is the sensor normal?	Go to step 4.	Replace the evaporator sensor. <Ref. to AC-80, REMOVAL, Evaporator Sensor.>
4 CHECK PRESSURE SWITCH. Check the pressure switch connection.	Is the connector normal?	Go to step 5.	Repair the connector.
5 CHECK PRESSURE SWITCH. Using the Subaru Select Monitor, check "Pressure Switch" of the current data from Air Conditioning Diagnosis.	Does the data indicate normal?	Go to step 10.	Go to step 6.
6 CHECK AMOUNT OF REFRIGERANT PRESSURE. Check the refrigerant pressure. <Ref. to AC-22, REFRIGERANT GAS PRESSURE INSPECTION, PROCEDURE, Refrigerant Pressure with Manifold Gauge Set.>	Is the refrigerant pressure normal?	Go to step 7.	Perform repair according to refrigerant pressure inspection.
7 CHECK CONNECTOR. Check poor contact of A/C control panel connector.	Is the connector normal?	Go to step 8.	Repair the connector.
8 CHECK FUSE. 1) Turn the ignition switch to ON. 2) Remove a fuse in the fuse & relay box. 3) Check the fuse.	Is the fuse normal?	Go to step 9.	Replace the fuse.
9 CHECK PRESSURE SWITCH SIGNAL. 1) Turn the ignition switch to OFF. 2) Disconnect the A/C control panel connector. 3) Turn the ignition switch to ON. 4) Measure the voltage between A/C control panel connector terminal and chassis ground. Connector & terminal <i>(i88) No. 11 (+) — Chassis ground (-):</i>	Is the voltage 10 V or more?	Replace the A/C control panel. <Ref. to AC-44, REMOVAL, Control Panel.>	<ul style="list-style-type: none"> • Check for open or short circuit in the harness between fuse and A/C control panel. • Check for poor contact of pressure switch connector.
10 CHECK CAN COMMUNICATION CIRCUIT. Using the Subaru Select Monitor, check "Air Condition System" of the current data from Engine Diagnosis.	Does the data indicate ON?	Go to step 12.	Go to step 11.
11 CHECK CAN COMMUNICATION CIRCUIT. Perform the diagnosis for LAN system. <Ref. to LAN(diag)-2, PROCEDURE, Basic Diagnostic Procedure.>	Is the system normal?	Repair it according to DTC of LAN system.	Replace the A/C control panel. <Ref. to AC-44, REMOVAL, Control Panel.>
12 CHECK A/C RELAY ON SIGNAL. 1) Disconnect the ECM connector. 2) Turn the ignition switch to ON. 3) Measure the voltage between ECM connector terminal and chassis ground. Connector & terminal Engine type: FA <i>(B134) No. 1 (+) — Chassis ground (-):</i> Engine type: EJ <i>(B135) No. 35 (+) — Chassis ground (-):</i>	Is the voltage 10 V or more?	Go to step 13.	<ul style="list-style-type: none"> • Check for open or short in the harness between pressure switch and ECM. • Check poor contact of A/C relay connector. • Check the A/C relay. <Ref. to AC-33, INSPECTION, Relay and Fuse.>

Diagnostics with Phenomenon

HVAC SYSTEM (AUTO A/C) (DIAGNOSTICS)

Step	Check	Yes	No
13 CHECK A/C RELAY ON SIGNAL. 1) Start the engine. 2) Turn the A/C switch to ON. 3) Turn the temperature control dial at maximum cool position. 4) Measure the voltage between ECM connector terminal and chassis ground. Connector & terminal Engine type: FA (B134) No. 1 (+) — Chassis ground (-): Engine type: EJ (B135) No. 35 (+) — Chassis ground (-):	Is the voltage 0 V?	Go to step 14.	Replace the ECM.
14 CHECK MAGNET CLUTCH POWER SUPPLY CIRCUIT. 1) Stop the engine. 2) Disconnect the magnet clutch connector. 3) Start the engine. 4) Turn the A/C switch to ON. 5) Turn the temperature control dial at maximum cool position. 6) Measure the voltage between magnet clutch connector terminal and chassis ground. Connector & terminal (F24) No. 1 (+) — Chassis ground (-):	Is the voltage 10 V or more?	Check the magnet clutch.	<ul style="list-style-type: none"> • Check for open or short circuit in the harness between fuse and magnet clutch. • Check poor contact of A/C relay connector. • Check the A/C relay. <Ref. to AC-33, INSPECTION, Relay and Fuse.>

11.UNABLE TO SWITCH SUCTION VENTS

TROUBLE SYMPTOM:

Inlet opening does not switch RECIRC → FRESH or FRESH → RECIRC each time pressing the FRESH/RECIRC switch.

TROUBLE CAUSE:

Intake actuator failure.

Step	Check	Yes	No
1 VISUALLY CHECK INTAKE DOOR OPERATION. 1) Remove the glove box. <Ref. to EI-63, REMOVAL, Glove Box.> 2) Visually check the intake door operation by operating the FRESH/RECIRC switch.	Does the intake door operate normally? Is the portion between intake door and intake door case sealed completely?	System is normal.	Go to step 2.
2 CHECK A/C CONTROL PANEL. 1) Turn the ignition switch to ON. 2) Using the Subaru Select Monitor, check "Fresh/Recircle Air Door Actuator Position Target" of the current data from Air Conditioning Diagnosis. 3) Operate the FRESH/RECIRC switch.	Does "Fresh/Recircle Air Door Actuator Position Target" indicate 0 ↔ 100?	Go to step 3.	Replace the A/C control panel. <Ref. to AC-44, REMOVAL, Control Panel.>
3 CHECK DTC. 1) Turn the FRESH/RECIRC switch to RECIRC, and leave for 16 seconds or more. 2) Read the DTC using Subaru Select Monitor.	Is DTC B14E9, B14EA and B14EB displayed?	Perform the diagnosis according to DTC.	Go to step 4.
4 CHECK DTC. 1) Turn the FRESH/RECIRC switch to FRESH, and leave for 16 seconds or more. 2) Read the DTC using Subaru Select Monitor.	Is DTC B14E9, B14EA and B14EB displayed?	Perform the diagnosis according to DTC.	System is normal.

Diagnostics with Phenomenon

HVAC SYSTEM (AUTO A/C) (DIAGNOSTICS)

12.UNABLE TO SWITCH VENTS

TROUBLE SYMPTOM:

- Unable to switch blow vents.
- Outlet opening does not switch in the sequence of FACE → B/L → FOOT → F/D after operating the mode switch or mode dial.

TROUBLE CAUSE:

Mode actuator failure.

Step	Check	Yes	No
1 CHECK A/C CONTROL PANEL. 1) Turn the ignition switch to ON. 2) Using the Subaru Select Monitor, check "Mode Door Actuator Position Target" of the current data from Air Conditioning Diagnosis. 3) Operate the air flow control switch.	Does the value of "Mode Door Actuator Position Target" change?	Go to step 2.	Replace the A/C control panel. <Ref. to AC-44, REMOVAL, Control Panel.>
2 CHECK DTC. 1) Turn the air flow control switch to DEF, and leave for 16 seconds or more. 2) Read the DTC using Subaru Select Monitor.	Is DTC B14E5 and B14E6 displayed?	Perform the diagnosis according to DTC.	Go to step 3.
3 CHECK DTC. 1) Turn the air flow control switch to VENT, and leave for 16 seconds or more. 2) Using the Subaru Select Monitor, read DTC of A/C control panel.	Is DTC B14E5 and B14E6 displayed?	Perform the diagnosis according to DTC.	System is normal.

Diagnostics with Phenomenon

HVAC SYSTEM (AUTO A/C) (DIAGNOSTICS)

13.ILLUMINATION DOES NOT ILLUMINATE OR CANNOT BE DIMMED

TROUBLE SYMPTOM:

Even when the lighting switch is operated, the illumination does not come on. Even when the illumination control is operated, the illumination does not dim.

TROUBLE SYMPTOM:

Open circuit in illumination circuit

WIRING DIAGRAM:

Clearance Light and Illumination Light System <Ref. to WI-115, WIRING DIAGRAM, Clearance Light and Illumination Light System.>

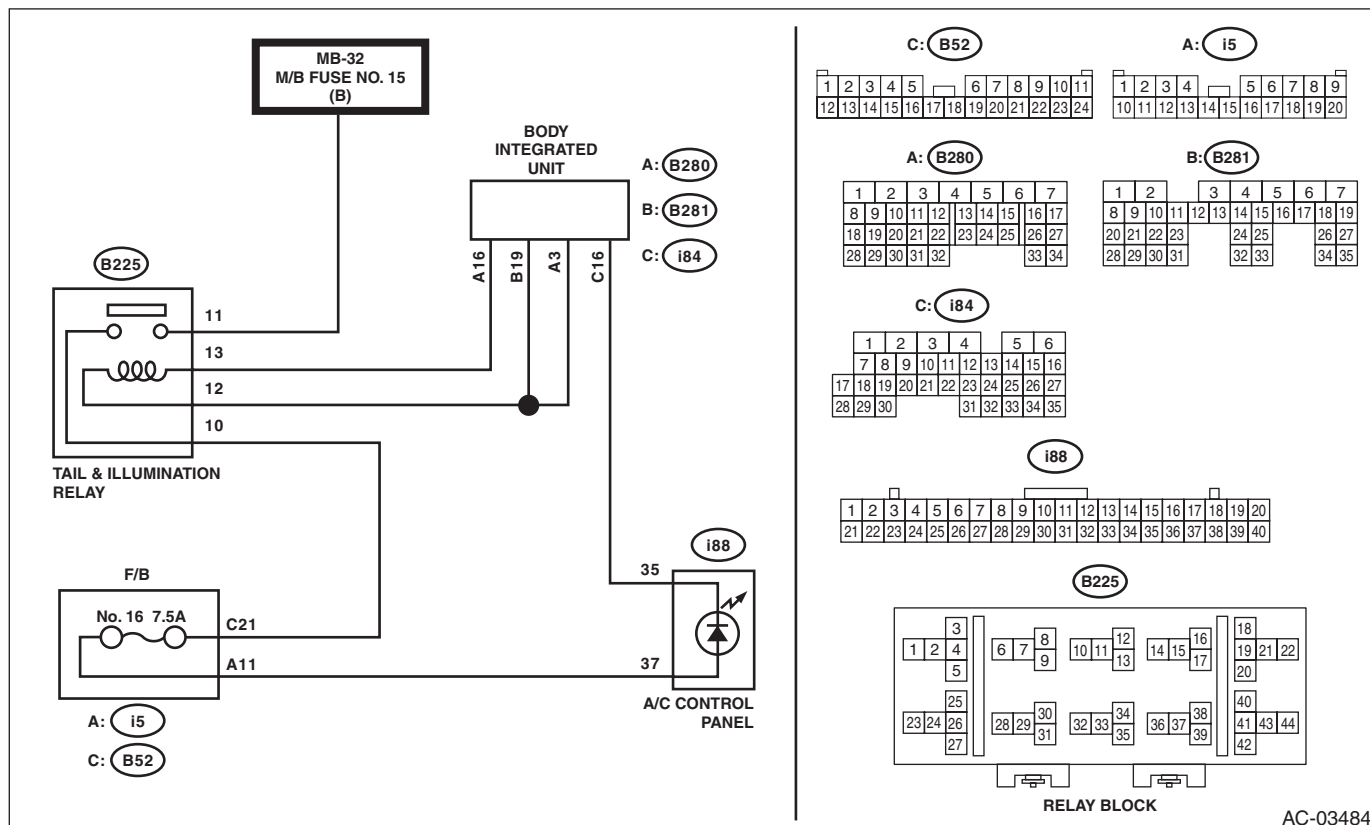

Step	Check	Yes	No	
1	CHECK ILLUMINATION. Make sure that all illuminations except A/C come on.	Do other illuminations come on.	Go to step 2.	<Ref. to LI-10, INSPECTION, Clearance Light and Illumination Light System.>
2	CHECK CONNECTOR. Check for poor contact of connector.	Is there poor contact?	Repair the connector.	Go to step 3.
3	CHECK HARNESS. 1) Turn the lighting switch to ON. 2) Using a tester, measure the voltage between the A/C control panel connector and chassis ground. Connector & terminal (i88) No. 37 (+) — Chassis ground (-):	Is the voltage 10 V or more?	Go to step 4.	Repair or replace the open circuit of harness.
4	CHECK HARNESS. 1) Turn the lighting switch to OFF. 2) Measure the resistance between A/C control panel connector and body integrated unit connector. Connector & terminal (i88) No. 35 — (i84) No. 16:	Is the resistance less than 10 Ω?	Go to step 5.	Repair or replace the open circuit of harness.

Diagnostics with Phenomenon

HVAC SYSTEM (AUTO A/C) (DIAGNOSTICS)

Step	Check	Yes	No
5 CHECK A/C CONTROL PANEL UNIT. Check the A/C control panel. <Ref. to AC-44, REMOVAL, Control Panel.>	Is A/C control panel OK?	A/C control panel illumination circuit is normal.	Replace the A/C control panel. <Ref. to AC-44, REMOVAL, Control Panel.>